



I3E
South East Europe TCP

Best Practice Report

Energy Harvesting for Mobile Eco-Efficient Wireless Sensor Networks

Document type : Best Practice Report
Document version : Final
Document Preparation Date : January 27th, 2011
Classification : Internal
Contact :
Project co-ordination : Profactor GmbH
Deliverable Responsible : Profactor GmbH

--	--

Best Practice Report

Rev.	Content	Resp. Partner	Date
0.1	Creation of document	Profactor	27.01.2011

Everybody please state revision index and short description of what has been done + partners involved and date.

Final approval	Name	Partner
Reviewer		

1. Best Practice Title

Energy Harvesting for Mobile Eco-Efficient Wireless Sensor Networks

2. Location of Best Practice

Country, region, town

Austria, Upper Austria, Steyr

3. Best Practice Executive Summary

Describe briefly (max 10 lines) the GP context (partnership, funding, objectives, approach followed, results)

Within the national funded FIT IT Embedded Systems project ECO-SENSOR, project partners (Profactor, Pöttinger, University of Linz, Exler Elektronikentwicklung) break up the critical dependency of remote wireless sensor networks from traditional battery technology. Based on the concepts of retrieving electrical energy from vibrating machinery and enabling ultra-low power wireless transmission of arbitrary sensor information, the design of this embedded modular base unit opens a variety of technological challenges going far beyond state-of-the-art. Since ECO-SENSORS are energy-autonomous, no additional energy has to be provided for both, sensing operation and wireless transmission. The ECO-SENSOR project (i) enables the reliable integration of dense wireless sensor networks for optimal condition monitoring and process control, (ii) accelerates engineering and integration times by totally eliminating wiring efforts, (iii) increases operational machining safety, (iv) dramatically reduces machine break-downs and maintenance costs and (v) allows for accessing sensors in otherwise not reachable areas.

The resulting prototype was able to supply the WTU and the sensor during working conditions.

4. Best Practice Classification

Good Practice Theme

X Research Transformed to Innovative Product

- Research Transformed to Innovative Service*
- Research Transformed to Innovative Methodology*
- Research Transformed to Innovative Production Process*
- Financial Mechanism for Transformation of Research to Innovation*
- Support Mechanism for Transformation of Research to Innovation*
- Other (describe)*

Good Practice Research / Application Areas

X Industrial / Manufacturing Systems

- Industrial Informatics and Communications*
- Intelligent Devices*
- X Distributed Control Systems**
- Flexible Manufacturing Systems*
- Embedded Systems*
- X *Industrial Embedded Systems***
- Nomadic Environments*

- Private Spaces*
- Public Infrastructures*

5. Description of Best Practice

5.1 Best Practice Context

Overall background of the Best Practice. Location, socio-economic, technical & policy background of the BP (max 10 lines)

PROFACTOR is an Austrian research company located in Steyr and focuses on developing new methods for integrated production technologies. PROFACTOR is the executive organization of the VPTÖ, an association for production in Austria led by CEOs of leading companies (BMW, MAN, VATECH, Hilti, MIBA etc.). Approx. 250 companies are partnering with PROFACTOR. About 85 scientists of various disciplines conduct research to improve the competitiveness of the production industry and to strengthen mainly the Austrian industrial region. PROFACTOR has a broad spectrum of competencies including Embedded Systems as well as Smart & Adaptive Structures.

With the additional expertise and reputation gained in the project ECO-SENSOR, the participants will increase their strength in related research topics and increase their chances for success in EC research programs: PROFACTOR and ICIE as RTDs, PÖTTINGER and EXLER as a main technology provider or end-user.

The Austrian dimension and the complementarity can best be seen by the fact that no major company is dealing with ECO-SENSOR technology for condition monitoring and process control in Austria, since this technology requires multi-disciplinary expertise in embedded systems, piezoelectric devices, ultra-low power electronics and wireless sensor networks. The ECO-SENSOR consortium builds upon the background of research and development work, which has been carried out by PROFACTOR and ICIE, but also upon the overall expertise by PÖTTINGER and EXLER. E.g. some research on embedded systems, piezoelectric devices and electronics will build upon results of the projects "MESACTIF" and "VIBE-LESS" within the FIT-IT: Embedded Systems programme.

5.1.1 Policy Elements

What are the policy initiatives that have influenced the contextual environment of BP: innovation promotion policies, research funding policies, certification etc. as well as relevant tools (max 10 lines)

PROFACTOR and ICIE have gained large experience in dissemination of scientific results from past and ongoing EC RTD and national funded projects. The partners use all of their available channels to media and press to make the project and its innovative results visible to an international audience. The following dissemination activities are envisaged to strengthen the visibility of the project and to circulate non-confidential results to stimulate academic and industrial research:

- Specific presentations at major industrial fairs to reach decision-makers.
- Presentations at (inter-)national conferences to strengthen visibility (e.g. SPIE Smart Structures and Materials)

- Publications and journal articles to spread scientific results
- Web presentation of the project (including an area for the business interest group)
- Usage of other media to raise public awareness (press, local TV channels)

The consortium accompanies the RTD approach with a coherent dissemination and use strategy. Since the RTD work is pre-competitive, the consortium pursues an open policy:

most information is public to generate the awareness of the new possibilities. The Dissemination Manager at ICIE is in charge for coordinating all activities. To balance the responsibility to publish research results against potential conflicts with IPR handling, partners provide information about planned publications to the consortium and the DM. The prime objective is to maintain and to extend the outstanding research position of the partners with research results and expertise obtained by this project and to take up into follow up research projects.

➤ **Publications:**

- Oral presentation of the ECO SENSOR technology concept at the “ACCM – Global Scientific Exchange, May 2009, Linz, Austria
- Oral presentation of the ECO SENSOR technology concept at the EEEfCOM, June 26-28, 2009, Ulm, German, High Frequency electronics, components, modules and EMI, trade fair, workshop and developer forum
- Oral presentation of the ECO SENSOR technology concept at the „Frauen in die Technik“-Schnuppertage, February 2009, Linz
- PR article on the ECO SENSOR technology concept, published online July 7 2009 in “Presse Box”, “APA”, “Rundschau”, “Computerwelt” and “Der Standard”
- PR Artikel, print publication, published on July 9 2009 in „ÖIAV“
- Müller G., Rittenschober T., Springer A.: “A wireless sensor network using energy harvesting for agricultural machinery”. E & I Elektrotechnik und Informationstechnik, Volume 127, Number 3, p39-46, March 2010.
- Müller G., Möstl G., Springer A., et. al.: “Energieautarke drahtlose Sensornetzwerke für landwirtschaftliche Maschinen”. Proc. of “Mikroelektronik Tagung 2010”. p.212-218. TU-Wien, April, 2010.
- Müller G., Springer A.: “Energieautonome drahtlose Sensoren im Einsatz auf landwirtschaftlichen Maschinen”, Prof. of “Industriellen Symposium Mechatronik” (ISM`10), p94-96., Linz, Nov. 2010.
- Posterpresentation: Müller G., Möstl. G. Springer A., et.al.: “Energieautarke drahtloses Sensornetzwerke für landwirtschaftliche Maschinen” Posterpräsentation im Rahmen der ME-Tagung 2010, TU-Wien, April 2010.
- Oral presentation: Müller G., Springer A.: “Energieautonome drahtlose Sensoren im Einsatz auf landwirtschaftlichen Maschinen”, Vortrag im Rahmen des “Industriellen Symposium Mechatronik”, 2010-11-18, Linz.

- **Patents:** One pending patent at the Deutsches Patent- und Markenamt filed on April 7 2008, reference number: DE 10 2008 017 572 A1, title: "Piezo-Kristalle an der Landmaschine"

5.1.2 Socio-economic & Other factors

Other contextual factors such as customer / target market addressed, international validity, customer density, economic conditions, customer values, research area addressed (max 10 lines)

Despite the agricultural industry, ECO-SENSOR technology also offers a great potential for customers in the complementary fields of machine construction:

- SALES INCREASE FOR (AGRICULTURAL) MACHINE VENDORS

By providing up-to-date, innovative agricultural technology, PÖTTINGER provides a valuable contribution towards increasing productivity in agriculture. A key factor of success is innovation and machines with highest reliability: This can be achieved by integrating more sensor devices for condition monitoring and process control. ECOSENSOR technology enables a higher integration of plug & play sensor networks yielding a further unique selling proposition.

- REDUCTION OF RUNNING COSTS FOR END-USERS

Since ECO-SENSORS are energy-autonomous, no additional energy has to be provided for both, sensing operation and wireless transmission.

- RAPID DEVELOPMENT AND LESS TIME-TO-MARKET

ECO-SENSORS accelerate engineering and integration times for process control by totally eliminating wiring efforts and by facilitating to handle system complexity. Faster introduction of new generations of agricultural machines will enable OEMs to become leaders in specific market segments, since market and economy are becoming increasingly volatile, unpredictable and radically changing.

- DECREASE IN AGRICULTURAL MACHINE BREAK-DOWNS

ECO-SENSOR technology focuses on energy-autonomy and wireless transmission, as a result, cable breaks or short-circuits of connecting cables can be excluded.

Therefore, ECO-SENSOR technology enables a reliable integration of dense sensor networks for condition monitoring, which will lead to an increase in operational machining safety and will reduce machine break-downs and maintenance costs.

5.2 Objectives

Aim of the project, specific objectives & strategies to achieve these objectives (max 10 lines)

The goal of the project is to break up the existing critical dependency of remote wireless sensor networks from traditional battery technology which cannot keep up with the increased performance of embedded computing systems. Hence, a radically innovative base technology for next-generation energy-autonomous wireless sensor networks will be developed, which are imperative for process control and condition monitoring in future mobile agricultural farming machines.

Best Practice Report



6. Process

Describe the project including key concepts and the overall approach followed. Indicate project end users, target market, main project phases, problems encountered and solutions, problem resolution (max 10 lines)

The project ECO-SENSOR breaks up the critical dependency of remote wireless sensor networks from traditional battery technology which cannot keep up with the increased performance of embedded computing systems. Hence, a radically innovative base technology for next-generation energy-autonomous wireless sensor networks was developed, which is imperative for reliable process control and condition monitoring in future mobile agricultural farming machines as well as in other industrial domains.

Within the project a full demonstrator consisting of the elements Mechanical Energy Conversion Unit (MECU), Electric Harvesting Unit (EHU), WTU (Wireless Transmission Unit) as well as Base Stations has been developed and tested within field -tests (Poettinger). These tests have been carried out on different rural and working areas and over different working periods.

The generated energy of the MECU (Profactor) after the developed EHU (Exler) is $>1\text{mW}$ (which is significantly more than the originally specified value) under working conditions of driving on a field.

Based on that available energy, the built system allows to transmit sensor signals (acceleration, temperature) linked to the functionality of a specific harvesting machine (loader wagon). The transmission of information was realised by an ultra low power wireless sensor system and network (ICIE), which allows to transmit the collected information from the rear end of the loader wagon to the main control unit of the loader wagon. Through intensive research an energy consumption of $< 200\ \mu\text{W}$ was achieved by the wireless unit.

6.1 Project Design

Project design based on targeted market complete understanding, project structure, policies and procedures, management and implementation actions (max 10 lines)

The ECO Sensor consists of 3 main parts.

- MECU (Mechanical Energy Conversion Unit)
- EHU (Energy Harvesting Unit)

- WTU (Wireless Transmission Unit)

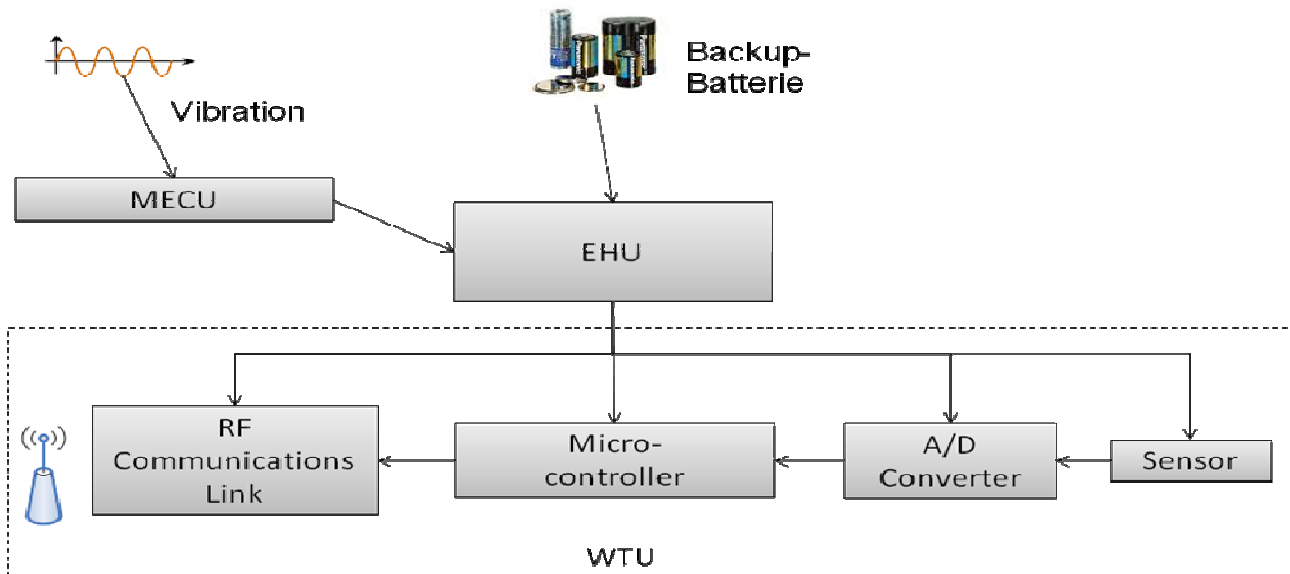

The energy- autonomous sensor (Eco- Sensor) is powered by mechanical vibrations that are available on nearly every device with moving parts. The conversion from mechanical energy to electrical energy is done by a piezo- element bonded on a beam. The beam is matched to the vibrations to get the optimal power output. This part is called MECU (Mechanical Energy Conversion Unit).

The voltage generated by the MECU is not directly useable for a microcontroller ore other electronics. Therefore an EHU (Electric Harvesting Unit) was build. It manages the energy storage, the backup-battery management and provides the constant voltage source for the WTU (Wireless Transmission Unit). The WTU is responsible for the radio transmission and the scanning of the sensors with a minimum power consumption.

6.2 Project Management

Activities relevant to project coordination and management, project documentation and reporting, quality control, validation and verification (max 10 lines)

The project management approach of the project ECO-SENSOR is supporting a clear distribution of responsibilities, which is transparent to all partners. It is based on management techniques that are well known to all partners and which have been successfully applied in previous national and/or international projects. Project partners have gained large experience in leading national and European funded research projects (FIT-IT ES MESACTIF, FIT-IT ES VIBE-LESS, FP6 IP DECOS, etc). The primary aim of this management structure is to be capable of responding to the needs of an FIT-IT project without being intrusive or costly. A lean management procedure has been chosen to be effective, since most of the partners have already cooperated in previous projects and they have established a very good understanding during the work for this proposal.

Project Control Board and leading roles within ECO-SENSOR:

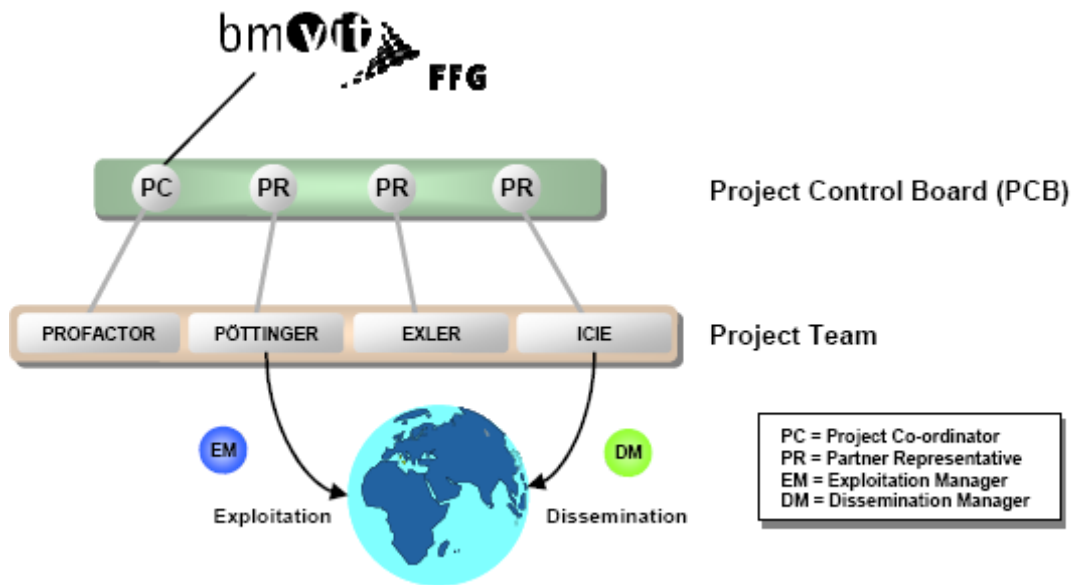

6.3 Project Implementation

Main elements associated with the project implementation. Realization of new idea, or new technological realization or improvement / novelty to known technology and means to achieve this. Innovation associated with the project realization in terms of new products, services, methodologies. Marketing, advertising and customer service. (max 10 lines)

The key elements and technological decisions within the proposed technical solution can be summarized as follows:

- Embedded system design of completely self-powered, i.e. energy-autonomous wireless sensor networks that do not require conventional replaceable, ecologically critical power supplies
- Dedicated protocol solutions for wireless sensor networks ensuring real-time capability and ultra-low power operation
- Self-sensing: extracting sensor information from the energy harvesting unit itself
- Lowest-power energy conversion technology from mechanical vibration energy into electrical using piezoelectric technology
- Innovative design of optimization algorithms for optimal sensor placement to secure 100% sensor dependability during machine operation
- Sophisticated adaptive embedded electronic solutions which are capable of selectively controlling and shutting down their different building blocks for enhancing energy efficiency

6.4 Project Evaluation

Project feedback mechanisms and evaluation mechanisms. (max 10 lines)

ECO-SENSOR technology will be tested and validated by means of laboratory tests on each functional unit and field tests on agricultural farming machines.

7. Description of Research team/Institution

Short description of R&D team and institution (max. 10 lines)

PROFACTOR (Profactor Produktionsforschungs GmbH): The group for Smart & Adaptive Structures is carrying out the research tasks. It has long-term expertise in mechatronics, distributed embedded systems and structural control with emphasis on vibration control. PROFACTOR coordinates the project and will scientifically contribute to piezoelectric arrays for optimal sensing and energy harvesting and embedded low-power electronics.

PÖTTINGER (Alois Pöttinger Maschinenfabrik Ges.m.b.H.): PÖTTINGER provides (i) expertise concerning robust agricultural machine development, (ii) information about customer specific needs, (iii) vibration measurements as a basis for optimal sensor placement and (iv) is responsible for performing ECO-SENSOR field tests for the targeted agricultural machine.

ICIE (Johannes Kepler University Linz – Inst. for Communications and Information Engineering): Within the proposed project, ICIE will cover the development of a wireless link that is high energy efficient, robust even in harsh agricultural environment, real-time capable and can handle multiple sensor nodes. The work of ICIE within the proposed project perfectly matches past and current research and expands its scope to wireless communications for specialized sensor network applications.

EXLER (Dr. Roland Exler Elektronikentwicklung): EXLER will contribute its expertise concerning the development of embedded electronics for energy harvesting purposes. Applications using wireless technology have been developed as well as amplifiers for piezoelectric materials used as actuators. Thus the fields of interest in the project are well known areas of work simplifying cooperation with the project partners.

8. Applied Financial Mechanism

Describe financial mechanisms applied in transformation of research into innovation within BP, as well as means of connecting scientific research team and financiers (max. 1000 char.)

Research is supported by the Austrian Research Promotion Agency (FFG) within the FIT IT Embedded Systems Program. The next step foresees presentation of the technology at international fairs and identifying further potential industrial sectors which the technology could be relevant for.

9. Impact and benefits

Describe achieved benefits of R&D team and/or enterprise implemented innovation, as well as impacts on institutional and policy levels. (max. 1000 char.)

PÖTTINGER:

The main interest of PÖTTINGER is the generation of radically innovative solutions as well as the extension of their technology landscape. PÖTTINGER is expecting to be able to open up new market chances in the agricultural domain, which is based on the following trends in the machining and agricultural industry:

(i) Enhanced condition monitoring and process control due to extended reliability of wireless sensor networks, (ii) increase in operational machining safety, (iii) reduction of machine break-downs and

maintenance costs as well as (v) sensor access in otherwise unreachable areas. These USPs will directly result in an additional estimated turnover of about 100 k€ per year.

Additionally, the project ECO-SENSOR leads to a new cooperation with research companies. In the case of a good project performance it is very likely that PÖTTINGER sets up subsequent projects in order to create a serial product out of the ECO-SENSOR technology.

PROFACTOR:

The main interest of PROFACTOR is to create new knowledge and expertise, to transfer it to industrial customers and partners and to gain reputation through the participation within the FIT-IT program, which is perceived as an “elite-research” program in Austria. Together with the FIT-IT Embedded Systems projects “MESACTIF” and “VIBE-LESS”, the FP6 IP “DECOS” and numerous short and medium term industrial projects, PROFACTOR can reach the critical mass of expertise to further strengthen its position in the European Research Area. PROFACTOR is confident that the ECO-SENSOR technology will open up new markets also for other industrial fields and will offer support at maturation. Additionally, there is a high potential for continuing research with ICIE, EXLER and PÖTTINGER beyond the project.

EXLER:

EXLER is confident that ECO-SENSOR technology could be easily extended to other fields for online machine monitoring. Since future systems get more and more complex, extending diagnostics built into machinery is a key issue to improve usability. Wireless transmission together with self powering may be a key feature to implement this efficiently mainly because of reduction in cabling costs.

After successful development EXLER plans to either sell to customer or run a licensing scheme. Depending on the results application to other fields of machine monitoring may be of interest. Additionally the R&D consortium will gain direct contact from other industrial branches which will lead to extra turnover in the consortium and strengthen their position as a distinguished provider for research & development.

ICIE:

Special strengths of ICIE are its expertise in wireless communication systems design, optimization for chip design, RFIC for mobile communications, and radar signal processing. ICIE is already positioning itself within the European Research Area and is confident to extend its expertise on wireless sensor networks and related engineering disciplines within the ECO-SENSOR project.

Co-operation with partners PÖTTINGER, PROFACTOR and EXLER will lead to further projects including other industrial partners from the machining and agricultural sector.

10. Sustainability

Provide information on sustainability of innovation after financial aid within implemented financial mechanisms, and some multiplier effects as replication and extension of the action performed in BP. Expected use of Best Practice and lifecycle considerations. (max. 1000 char.)

With the additional expertise and reputation gained in the project ECO-SENSOR, the participants increase their strength in related research topics and increase their chances for success in EC research programs: PROFACTOR and ICIE as RTDs, PÖTTINGER and EXLER as a main technology provider or end-user.

The Austrian dimension and the complementarity can best be seen by the fact that no major company is dealing with ECO-SENSOR technology for condition monitoring and process control in Austria,

since this technology requires multi-disciplinary expertise in embedded systems, piezoelectric devices, ultra-low power electronics and wireless sensor networks. The ECO-SENSOR consortium builds upon the background of research and development work, which is carried out by PROFACTOR and ICIE, but also upon the overall expertise by PÖTTINGER and EXLER. E.g. some research on embedded systems, piezoelectric devices and electronics will build upon results of the projects “MESACTIF” and “VIBE-LESS” within the FIT-IT: Embedded Systems program.

The ECO-SENSOR project will strengthen PROFACTOR within the area of smart systems and embedded electronics and ICIE’s position in the area of wireless sensor networks, which is an important topic in the currently proposed COMET K2 center ACCM (Advanced Center of Competence in Mechatronics). ICIE, PÖTTINGER and PROFACTOR are consortium members of ACCM. The work within ECO-SENSOR complements the proposed projects in the thematic area within ACCM. Cross-fertilization is strongly expected!

The Austrian mechanical engineering industry has a stronghold in machines, plants, and devices that perform complex processes such as steel production systems, agricultural machinery, and combustion engines. Know-how in the area of energy-autonomous wireless sensor networks to be established in ECO-SENSOR will also be of great interest to many other Austrian companies. Because the Upper Austrian industry has a strong focus on mechanical engineering, a considerable regional effect is to be expected!

Projects at the international level will be initiated in the near future and lead to a consistent development of the base technology with respect to requirements from different applications.

11. Repeatability and transferability

Lessons learned from the project implementation team. Repeatability and transferability of the project. (max. 1000 char.)

A fully integrated mechatronic approach is chosen to capture the interrelations between information technology, electronics and mechanical components, to be able to significantly optimize the resulting ECO-SENSOR technology with respect to its applications.

Despite the complexity of the technology, a small but agile consortium covering all the know how needed demonstrates the potential of an upcoming technology which enables highest integration of plug & sense sensor networks yielding an enhanced unique selling proposition.

12. Evaluation

Describe reasons and evaluation criteria why the described example is a best practice. (max. 1000 char.)

A fully integrated mechatronic approach is chosen to capture the interrelations between information technology, electronics and mechanical components, to be able to significantly optimize the resulting ECO-SENSOR technology with respect to its applications.

Despite the complexity of the technology, a small but agile consortium covering all the know how needed demonstrates the potential of an upcoming technology which enables highest integration of plug & sense sensor networks yielding an enhanced unique selling proposition.

Best Practice Report

13. Contact of research team/institution	14. Contact of financial mechanism facilitator
<i>Name, address, tel., fax, e-mail, URL</i>	<i>Name, address, tel., fax, e-mail, URL</i>
Profactor GmbH Im Stadtgut A2 4407 Steyr Tel.: +43 (0)7252 885 - 120 www.profactor.at	FFG - Austrian Research Promotion Agency Sensengasse 1 1090 Wien Tel.: +43 (0)5 7755 - 0 e-mail: office@ffg.at, www.ffg.at